

# Introduction to Electric Vehicle Transmissions

Dr. Hermann J. Stadtfeld

## Transmissions in Automobiles with Internal Combustion Engines

Traditional automotive transmissions are designed to adjust the engine speed to the speed of the driving wheels, required in order to achieve the desired driving speed. The engine speed of a modern internal combustion engine has a range for optimal efficiency between 1,000 and 2,500 rpm.

A midsize sedan with an outer tire diameter of 600mm has to rotate with a speed of 778 rpm in order to achieve a vehicle speed of 88km/h or 55mph,

$$n = 10^6 \cdot v / (D \cdot \pi \cdot 60)$$

whereas:

$n$  rotational wheel speed [rpm]

$v$  vehicle speed [km/h]

$D$  outer tire roll diameter [mm]

If the engine idle-speed is 600 rpm, and if the engine crank shaft output was directly connected to the wheels, then the vehicle speed would be:

$$v = n \cdot D \cdot \pi \cdot 60 / 10^6 = 600 \cdot 600 \cdot \pi \cdot 60 / 10^6 = 67.9 \text{ km/h (42.44 mph)}$$

One problem is that the engine torque in idle would not be sufficient to keep a vehicle moving at 67.9km/h (42.44 mph) on a level pavement. A second problem is encountered when the engine is instantly connected with the wheels at idle speed.

The vehicle would first jerk and then the engine would die. The torque characteristics of a combustion engine and an electric motor (Fig. 1) show the low-torque availability of a combustion engine at idle speed.

Even if a compliant element like a torque converter between engine and wheels is used, it would not be possible to control acceleration, speed and deceleration the way it is expected for safe driving. Besides all of these obstacles, the fuel consumption of a vehicle without a transmission would be several times that of a vehicle today that is equipped with a multi-speed transmission.

The study of a simple driving sequence can already reveal all basic requirements for an adaptive transmission element between engine and wheels. When the vehicle starts from a full stop, the engine has to increase its speed from 600 rpm idle to 1,500 rpm in order to develop enough torque for the acceleration of the standing vehicle. At the beginning, a hydraulic torque converter or a slip clutch will connect the rotating crankshaft of the engine with the not-yet-rotating gears in the transmission that are connected to the wheels — which also do not yet rotate. At this instance, the transmission has to provide a sufficient reduction, such

that the torque converter output torque is amplified enough to accelerate the vehicle from zero speed to a moving condition. Shortly after that, when the vehicle is driving between 10 and 20 km/h (6.25 and 12.5 mph), the transmission shifts into a higher gear because the engine rpm would have to double when the vehicle speed is 30 km/h (18.75 mph) and be about 6 times higher (=9,000 rpm) when the vehicle reaches the desired 88 km/h (55 mph). Such a high engine speed would be undesirable in many ways. The fuel consumption of the vehicle would become extremely high and the exhaust and noise emission would also reach unacceptable levels. A high-revving engine would also be subject to high wear and to many possible mechanical failures.

In order to keep the engine running in a desirable range between 1,000 and 2,500 rpm, the transmission will shift up about 7 times until the vehicle reaches 88 km/h (55 mph). After the transmission shifts into a higher gear, the engine rpm drops, for example, down to 1,000 rpm, while the gas pedal is kept at a steady position. The higher gear (lower ratio) requires more load from the engine that initiates the rpm drop. As the vehicle continues to accelerate, the engine rpm increases proportionally with the vehicle speed, and loses torque until the next shift occurs at, for example, 2,500 rpm. Now the engine speed drops to 1,000 rpm and the acceleration torque increases again. The load hysteresis is the highest at the low engine rpm and the lowest at the high rpm. The gas pedal position creates this hysteresis while the driver signals to the engine that either a faster or a slower speed is desired.

A cross-sectional cut through a modern, electronically controlled eight-speed automatic transmission is shown (Fig. 2). The input from the engine and the torque converter is on the right side of the transmission. The input shaft passes through three planetary stages that have two multiple-disk clutches on the right side and two multiple-disk clutches to their left that actuate the eight transmission ratios for forward driving. At the left side of

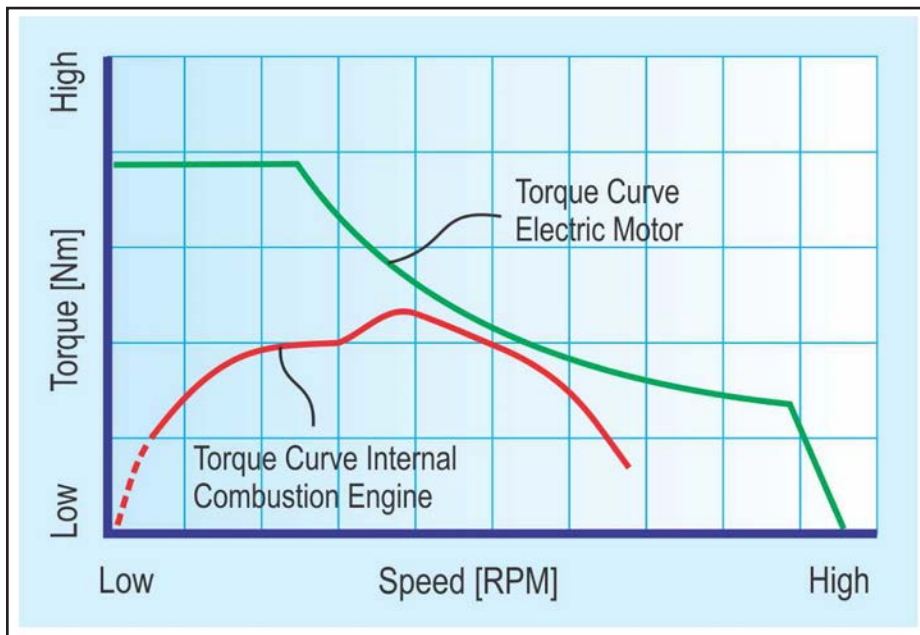

Figure 1 Torque versus speed, combustion engine and electric motor.

the transmission is one additional disk clutch that actuates the planetary stage to its left for reverse driving. The output shaft is exposed on the left side of the transmission.

**Conventional automotive drive trains.** A view of all transmission components in an all-wheel drive passenger car with a longitudinally oriented combustion engine is shown (Fig. 3). A transmission, similar to the one shown (Fig. 2, center-left), is used to adapt the engine speed to the wheels. One long propeller shaft connects the transmission output with the rear axle unit (right side). The rear axle reduces the transmission output speed by a constant factor (usually around three) and additionally re-directs torque and rotation from the input direction by 90° — which matches the wheel rotation direction. The rear axle unit output flanges are connected to the two rear wheels with drive shafts. Each drive shaft uses two constant-velocity joints in order to disconnect the mass inertia of all drive components from the wheels. The wheels are connected to space control arms that ensure a minimum of un-sprung weight on each wheel; low un-sprung weight enhances vehicle stability and driving comfort.

In order to also propel the front wheels, a transfer case is added to the output of the transmission. A second, shorter propeller shaft connects the front axle with the transfer case. The front axle and wheel suspension also follow the principle of minimizing the un-sprung weight of the individual wheel.

The concept in Figure 3 clearly demonstrates that typically, only one engine is used as a prime mover and only one transmission adapts the engine speed to the desired speed of the wheels. This central speed and power are then transferred to the driving wheels via propeller shafts and drive shafts. Equipping a vehicle with two combustion engines appears impractical. Internal combustion engines are rather large and require an infrastructure of connections for fresh air intake, gasoline lines, electrical, electronical and mechanical control, and actuation signals — as well as a complex exhaust system. Experiments in the past also showed that synchronizing two combustion engines is nearly impossible and poses many safety concerns.

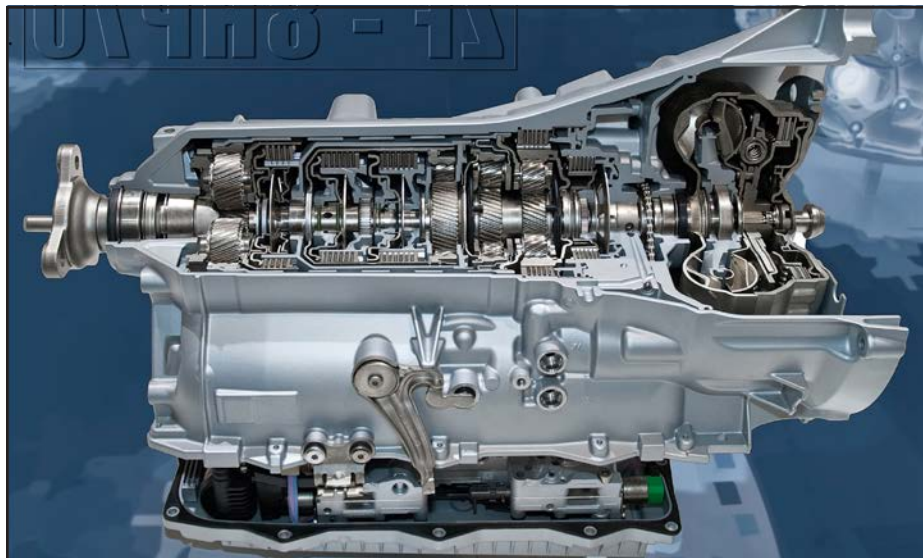

Figure 2 Eight-speed automatic transmission (Refs. 1–2).



Figure 3 Powertrain in an all-wheel drive sedan (courtesy ZF Friedrichshafen AG).

The strength of electric motors is their small size and their nearly non-existing infrastructure. The following sections will discuss these aspects and new possibilities presented by e-Drives.

**Transmissions in electrical vehicles.** Electric motors have a number of advantages versus internal combustion engines. The size of the latest high-performance motors that use rare earth magnets with many poles is very small compared to their HP or kW rating. Their peak torque is higher than that of combustion engines. Electric motors start with zero rpm and can develop high torques at low speeds. However, their speed for optimal performance regarding available energy and consumption of electricity is rather high. At a cruising speed of 88 km/h (55 mph), today's electric

vehicles operate, for example, at motor speeds of 10,000 rpm. The rotational wheel speed, at 88 km/h (55 mph), was given above with 778 rpm, which results in a 12.85 ratio between electric motor and wheels; the ratio at the same speed for a car with a combustion engine is 1.93 (engine speed equal to 1,500 rpm). This comparison shows that electric vehicles require more than six times the transmission ratio of a conventional car in order to deliver good performance and high efficiency.

If electric motors are built even smaller than today, this would reduce the cost for rare earth magnets and make the motors lighter and easier to integrate between the wheels of a vehicle. Electric vehicle manufacturers have already announced that electric vehicle motor development

will increase rpms to 20,000 within the coming four years, and further increase to 30,000 rpm before the year 2030. These high-speed motors require new bearing solutions and their copper windings have to be tighter and need to be wound with the highest accuracy in order to reduce vibration from unbalance and prevent the coils to take a “set” due to the high centrifugal forces. For the transmission solutions, this means higher ratios; the above mentioned ratio of 12.85 will have to increase up to 38.55 — and ever higher.

**Electric vehicle transmission design and manufacturing requirements.** Ratios are not the only different requirement between conventional and electric vehicle transmissions; the requirement portfolio also covers of course the criteria “power density,” “noise” and “efficiency.” Electric motors can deliver short bursts of peak torques which are several times as high as the nominal power rating. This provides the electric vehicle a sporty touch and makes it attractive to certain groups of consumers. The transmissions have to be able to handle these high peak torques during the vehicle’s entire life-cycle. Although, from a practical point of view, the efficiency should have the highest priority right after the strength of the gears, in reality the noise emission has been found to be of much higher priority for customers. Due to the high rpms of motor and gears, some vehicle owners notice strange high-pitch humming sounds they never experienced in a vehicle before. Some vehicle owners just complain that it is uncomfortable, while others claim that it puts a permanent ringing

in their ears, which does not go away after they leave their electric cars.

This means, for electric vehicle transmissions, that advanced manufacturing and gear mating technologies have to be applied. Gears have to be ground or hard skived and honed. Combinations of a honed and a ground gear, or a ground gear with a hard skived gear have proven to deliver the lowest noise emission and are also less likely to emit high pitch frequencies. Electric vehicle cylindrical gears will also require sophisticated topological flank surface optimizations that provide conjugate flank centers for optimal transmission characteristics, as well as high load carrying capabilities. Only the tooth boundaries in path-of-contact direction are relieved to prevent load concentration peaks under highest loads. Although hard skiving is not a common hard finishing process for cylindrical gears, it is about to have a breakthrough for internal transmission rings. These rings are not hard finished at present because grinding would require a miniature-sized grinding wheel. Today the internal teeth are finish-shaped or broached, and then either heat treated — with the goal of low distortions — or ion-nitrited. The nitrite only creates a 0.01 mm hard skin on the surface, but it guarantees very low distortions. It is also possible today, with the power skiving process, to perform a hard finishing operation after heat treatment by applying carbide hard skiving cutters.

Noise emission and high loads also put difficult requirements on the bearings and on the transmission housing design.

Even the smallest vibrations can become noise problems when the vibration finds a resonance in the surrounding vehicle components.

**Practically realized electric transmission examples.** All transmissions shown and discussed in this section are placed between the wheels of an axle — front and/or rear. Their output flanges are connected to the wheels with drive shafts that use constant velocity joints on both ends. In comparison to in-wheel motors, the un-sprung weight of the wheels and wheel suspension units is kept as low as in a modern, conventional car. High un-sprung weight will reduce the traction contact between tire and road and will also contribute the wheel to trample while driving on uneven or bumpy surfaces. The trample reduces driving comfort and the vehicle handling properties and therefore presents a safety risk.

A two-stage and single-speed electric vehicle transmission is shown without the electric motor (Fig. 4). The transmission ratio is 12.5 and cannot be changed in order to adjust to the driving speed or to traffic conditions. Single-speed transmissions are very well-suited for small-sized electric vehicles due to their small size and low weight, as well as the possibility to manufacture them cost effectively.

The transmission in Figure 4 requires only three shafts and six bearings. Due to the helix angle of all applied cylindrical gears, the bearings are either tapered roller bearings or angular ball bearings that are axially shimmed in order to achieve a light pre-load. This transmission is suited for driving one single axle of a two-wheel or both axles of an all-wheel drive vehicle.

The transmission (Fig. 5) presents a very interesting three-stage design that can accommodate a maximal ratio of 18. This transmission has a second, smaller-size motor that realizes, in connection with the planetary stage, a variation of the output speed of one wheel versus the other. This functionality not only replaces the conventional differential; it is also utilized to realize a high-efficiency torque-vectoring function.

The arrangement of the two motors facing each other, and the low width of the central transmission, accommodate a small distance between the output shafts



**Figure 4** Two-stage and single-speed electric vehicle transmission — ratio 12.5 (Ref. 3).

allowing for long drive shafts, which is a desirable condition.

The transmission (Fig. 6) is two-stage, two-speed — with a maximal ratio of 16. This transmission is very compact and requires very little extra space next to the electric motor; the differential with its four straight bevel gears is integrated in the final drive gear.

One of the differential outputs is visible at the right side of Figure 6. Because of the concentric orientation of the electric motor relative to the final drive gear of the transmission and the differential, the problem of transmitting the rotation from the second differential outputs to the left side of the motor is solved by using a hollow motor shaft where an extension shaft of the left differential output is placed. This puts the left output flange at the backside of the electric motor. The distance between the output flanges is larger compared to the transmissions shown (Figs. 4 & 5), but still allows for a reasonable length of the drive shafts.

A rather high reduction transmission, with the motor integrated within the same housing, is shown (Fig. 7); the maximal ratio of the transmission in Figure 7 is 20. The transmission has four reduction stages and can switch between two different ratios. The two multiple-disk clutches assume the differential function and can realize a torque-vectoring of the driven wheels. Each of the disk clutches is connected to one output shaft — one of which exits at the left side of the transmission directly with a drive shaft flange. In this transmission concept, the second output shaft is guided through a hollow motor shaft to the right-side drive shaft flange.

This transmission looks slick and clean, and is very well designed. The high ratio with the four-cylindrical gear-planetary stages — including the final drive gear set — requires the same amount of space as the electrical motor, which results in a significant width increase of this transmission. It may also be questioned, i.e. — does realizing the differential function with the multi-disk clutches present an adverse aspect regarding the concept of low energy consumption? Torque-vectoring should be done in certain driving conditions in order to improve traction and reduce or eliminate lateral sliding of the tires on the pavement (Ref. 7).



Figure 5 Three-stage variable ratio electric vehicle transmission — max ratio 18 (Ref. 4).

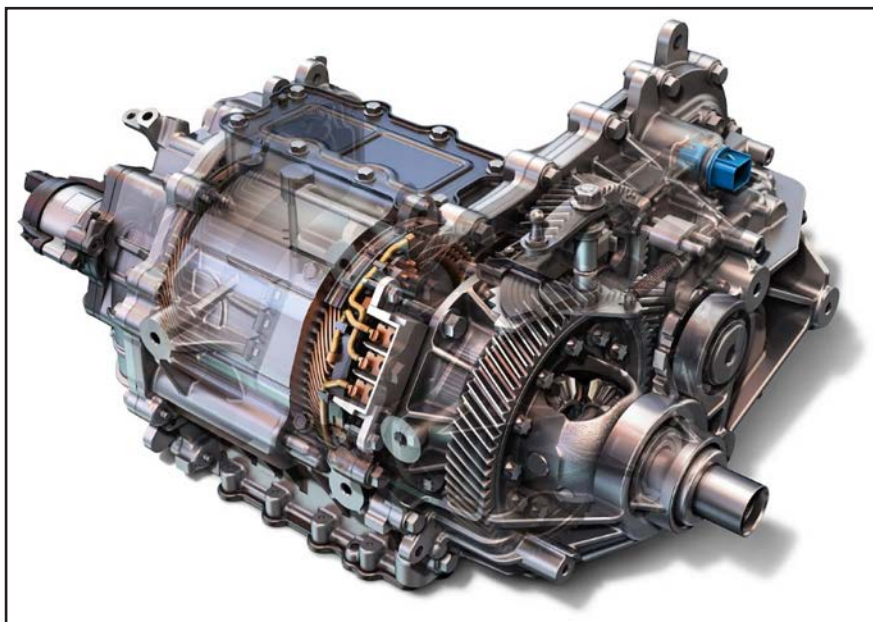

Figure 6 Two-stage and two-speed electric vehicle transmission — max ratio 7.05 (Ref. 5).

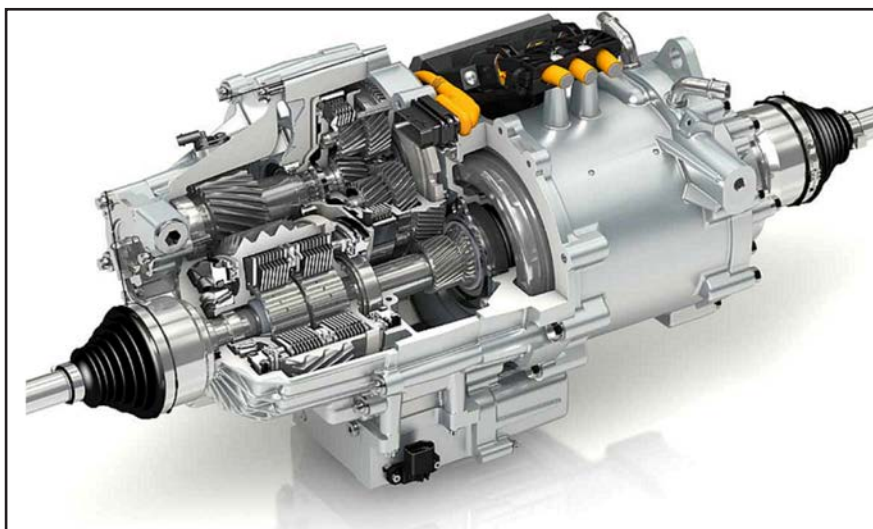

Figure 7 Four-stage and two-speed electric vehicle transmission — max ratio 20 (Ref. 6).

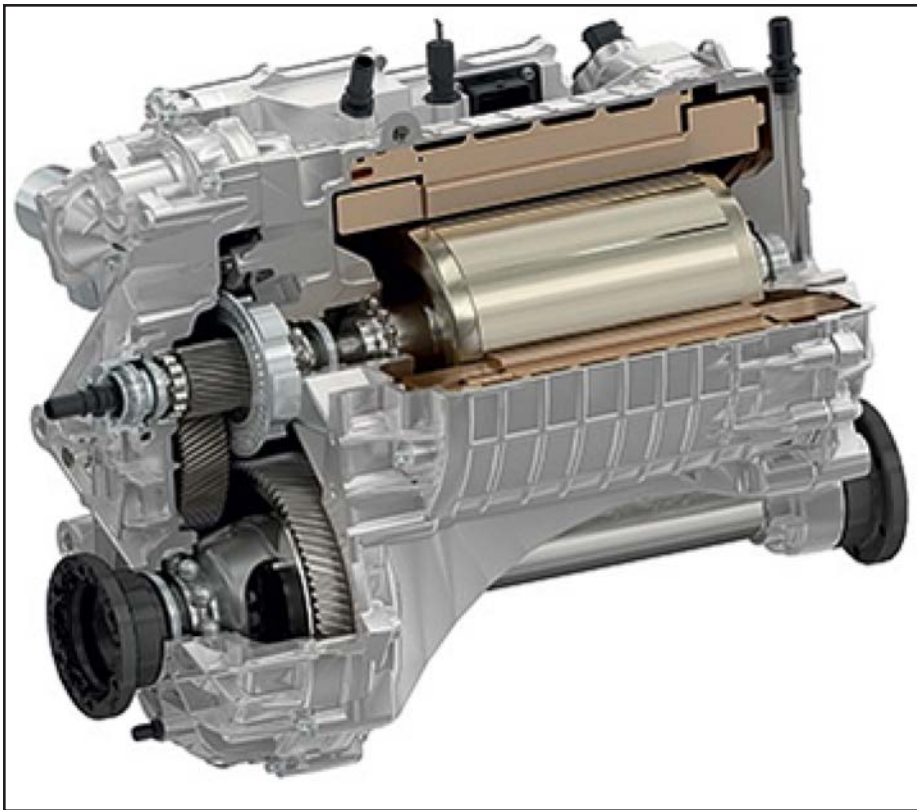

Figure 8 Two-stage and two-speed electric vehicle transmission—max ratio 12 (Ref. 8).

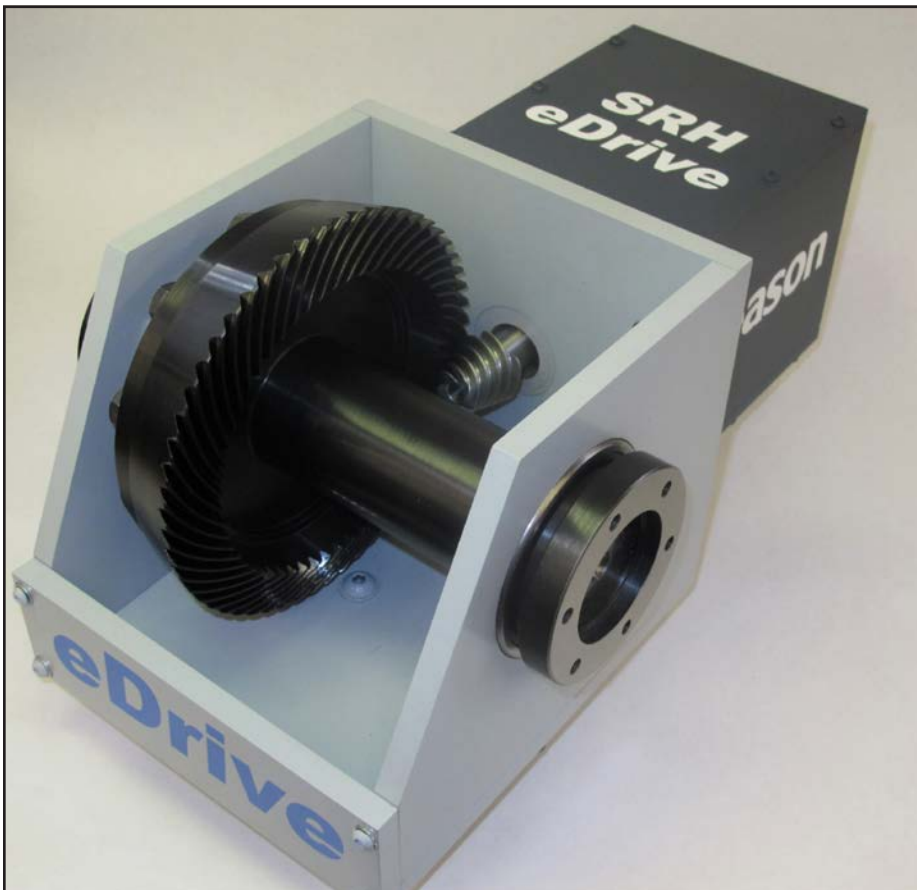

Figure 9 One-stage and single-speed electric vehicle transmission—max ratio 15 (Ref. 9).

Each torque-vectoring approach will burn energy from the motor between the sliding clutch disks. When the torque vectoring function is used to re-establish driving safety in an unsafe condition, then there is no alternative, which means the extra energy is well-spent. However, when the same function is used to emulate a differential—for example, when the vehicle is driving through a bend—then it contrasts with the traditional differential with virtually no friction due to the speed compensation with a very slow rotation of four straight bevel gears that have an efficiency rating of about 97%.

A small-diameter high-torque motor with a long rotor but a very small two-stage transmission that allows combining between two speeds is shown (Fig. 8). The differential unit is shown on the left, inside the final drive gear. The left drive shaft flange is directly connected to the left-differential side gear. Because the center of the differential unit is below the motor, a long shaft below the motor connects the right differential side gear with the output flange at the right side of the motor unit. This particular design represents an alternative to a more complex design where the connecting shaft of one side would have to pass through a hollow motor shaft as shown in the examples in Figures 6 and 7.

The stud above the left-side output flange is used to shift between the two gear ratios. The stud is part of a shaft that passes through a hollow gear shaft to actuate a synchronizing dog clutch. This principle has the advantage of minimal energy losses during gear shifting actions.

A very simplistic single-stage reduction utilizing a super reduction hypoid gearset is shown (Fig. 9); this transmission has a ratio of 12. Similar designs can realize ratios up to 15 without an increase of the gearbox size. The main advantage of this transmission is the small distance between the drive shaft flanges and the perfect symmetric weight distribution and heat radiation. Two shafts and four bearings make this transmission easy to build and cost-effective to manufacture.

Although hypoid gears are considered more difficult to manufacture, compared to cylindrical gears, there are certain advantages to the application of hypoid gears in electric vehicle transmissions.

The hypoid gears in Figure 9 are ground by using selective crowning. The selective crowning applies a so-called “Universal Motion Concept” that allows combining conjugate flank centers and relieved entrance and exit sections of the tooth mesh. This technology has been available in state of the art bevel gear manufacturing machines for many years and has proven to reduce load concentration while maintaining low meshing impacts under all load conditions.

In addition, advanced bevel gear grinding machines come with a high-frequency noise reduction feature, i.e. — “MicroPulse.” A three-axis pulsing strategy creates a certain favorable surface structure which is then phase-shifted from tooth to tooth according to a calculated mathematical function. A surface structure that is shifted from tooth to tooth ensures that no two equal tooth meshes can occur throughout an entire hunting tooth sequence, which is a number of pinion revolutions equal to the number of gear teeth. For the example in Figure 9 (60 ring gear teeth) this means 60 pinion revolutions have to pass until the structure-related sequence repeats. A MicroPulse pinion rolls with a Formate-ground ring gear without pulse structure. This combination compares directly to the requirements of electric vehicle transmission gears discussed previously.

**In-wheel electric motors.** The solutions presented previously place an electric motor connected to a transmission between the wheels of one axle. It appears that an attractive solution is to use a direct-drive motor on each driving wheel. There are no drive shafts required, nor is a differential for driving through curves or disk clutches for torque vectoring necessary.

An example for a direct-drive wheel hub motor is shown (Fig. 10) (Ref. 5). The large outer-diameter of the blue motor rotor helps to achieve high torques at low speed—without the need for a transmission. The higher speeds are also not critical, because they are equal to the moderate wheel rpms at a certain vehicle speed. Earlier, it is mentioned that the wheels will only rotate with about 600 rpm while the vehicle is driving a speed of 67.9 km/h (42.44 mph). The “pancake style” wheel hub motor therefore is a high-torque and low-speed motor.



Figure 10 In-wheel direct drive motor (Ref. 10).



Figure 11 Double-wheel hub motor with transmission (Ref. 11).

As mentioned, most electric vehicle manufacturers tend to go to higher-speed and lower-torque motors with the goal to maximize system efficiency and reduce weight, even if this is only possible in connection with a transmission. Obviously, the developer of in-wheel motors discovered certain phenomena that help to overcome the physical restrictions other electric vehicle designers encountered.

The un-sprung weight connected to each individual wheel is definitely higher than in the case of the central drive units discussed earlier, but the developer of this system created very compact motor units that might even be able to replace the brake disk and associated weight entirely.

A wheel hub drive unit that features

two motors that are connected to three planetary transmissions is shown (Fig. 11). The two motors can rotate in opposite directions in order to achieve an output rpm of zero. If both motors rotate in positive direction then, depending on the two motor speeds, each output speed between zero and the maximum driving speed can be achieved. If the first motor is a less-dynamic, high-torque motor and the second motor is a higher-dynamic, low-torque motor, then every driving condition can be efficiency optimized by the vehicle’s electronic control module (ECM), which can adjust the optimal speed combination between the two motors.

Problems occur due to the length and the weight of the drive unit in Figure 11. If this unit is assembled to a front axle,

then accommodating the steering will be difficult due to the length of the unit towards the center of the vehicle. Also, the un-sprung mass of this unit is rather high compared to the compact solution in Figure 10.

**Improved electric vehicle from in-wheel to central drive.** An example of a popular electric microcar is the Mitsubishi Miev (Fig.12). In 2006 the Miev was introduced with two in-wheel electric motors (Ref. 1). Even for this small-size vehicle, the in-wheel concept presented a number of problems. In order to make the Miev microcar attractive to buyers, Mitsubishi strived for a vehicle reach of 160km (100miles) per battery charge and an available output power of about 50 kW by achieving a maximum wheel torque of around 1400 Nm.

Besides the handling compromises due to the weight of the in-wheel motors causing trampling and lateral sliding of the driving wheels, the excessive energy consumption and the heat peaks of the in-wheel motors have been found to be difficult to eliminate. The heat peaks are initiated by short acceleration sprints that frequently occur in city driving. In slow-speed driving cycles the un-cooled wheel motors would require forced air or water cooling in order to stay below the temperatures that distort the wheels and changes the properties of the tire rubber.

Today, electric vehicle motor manufacturers promote rather high-speed motors in connection with multi-speed transmissions. Most of these motors can be operated without forced external cooling; their

weight is low and their efficiency with the required transmissions is excellent.

The latest Mitsubishi Miev edition for the model year 2020 has a central electric motor with a two-speed transmission and a maximum ratio of 7.065. The e-Drive unit is connected to the rear wheels with drive shafts with each having two constant velocity joints. The rear axle is a modern, independent three-link de Dion design, as is rather expected in luxury premium vehicles or in sports cars. The maximum motor output torque of 196 Nm feels high for such a small size car. However, the battery weight added to the vehicle components results in a curb weight for the Miev of 1090 kg, which gives a reasonable but not overly high torque-versus-weight ratio of 0.19 Nm/kg.

The departure from in-wheel e-Drives can also be seen more and more for mid-size sedans as well as for SUVs and electric sports cars. This shows a clear trend in transmission solutions with multiple speeds that can adapt the rpm of high-speed motors within their optimal efficiency and torque range, resulting in better electric vehicles—which not only avoids the use of gasoline but also minimizes the consumption of electrical energy.

**The Following Chapters of this Book**

The motivation for writing this book is based upon the many discussions and requests from electric vehicle builders regarding specific solutions which Gleason may be able to offer. These discussions made the requirement portfolio

of such transmissions more clear and Gleason scientists began to think in the direction of transmissions with high input speed and low output speed, using a minimum of transmission stages and allowing multiple reduction ratios.

Chapter 2 presents a revisiting of the basics in propelling vehicles with internal combustion engines, hybrids and electric vehicles; a major part of Chapter 2 is the comparison of overall efficiencies. Standard efficiency factors are used for each transmission element, and then the factors are multiplied to gain an overall efficiency. By using this technique, it becomes nearly secondary if the assumed efficiency factors are correct or slightly deviating from the latest effective values. The task of comparing different concepts to propel a vehicle can be accomplished with this strategy very well, because the same efficiency factors are used for the same transmission elements — independent from the vehicle concept. One example of this study is the hybrid without any transmission and wheel hub electric motors (Fig. 13).

The goal of Chapter 2 is to find motor and transmission concepts that result in high, overall efficiency. As alternative ways of propelling future vehicles are investigated, the concepts with the highest overall efficiency should be considered with a higher priority because there will be already a reduction of consumed energy before the details of hybrid, hydrogen or electric propulsion are even decided.

While Gleason Corp. began actively thinking about good electric vehicle transmission solutions, the idea was borne to present a first solution at the 2018 Japanese International Machine Tool Fair, i.e. — JIMTOF in Tokyo, Japan. Figure 14 shows one of the solutions presented at the JIMTOF.

Chapter 3 reports about this first solution, which was the application of high-reduction hypoids and super reduction hypoids (SRHs). At the JIMTOF Show, a closed loop development of transmission housing, shaft and bearings, as well as the SRH reduction and additional cylindrical gear shift ratios, was shown. The transmission design began in KISSsys and the hypoid design was conducted with the Gleason GEMS software. A closed loop optimization between KISSsys and GEMS



Figure 12 Mitsubishi Miev (Ref. 12).

for the optimization of deflections and contact forces uses a specially written dynamic XML interface that was demonstrated in life workshops during the show.

The first technical paper about SRH e-Drives was presented at the 2019 *Fall Technical Meeting of the American Gear Manufacturers Association (AGMA)* in October of 2019. Figure 14 shows one of the solutions presented in this paper. The high interest in technologically new and advanced transmission solutions with extremely high ratios and high efficiency led to the development of the reversed pericyclic transmission.

An example of a reversed pericyclic transmission is shown (Fig. 15). Significant advantages of pericyclic transmissions are the low relative sliding between the engaged tooth surfaces and the high contact ratio between the meshing gears. The low sliding velocity enables pericyclic transmissions to handle high speeds regarding surface damages and wear rather well. In common cases like the one shown in Figure 15, more than 10 pairs of teeth are engaged and contribute to the transmission of the output torque, which makes these transmissions insensitive to torque peaks and shock loads. A disadvantage of pericyclic transmissions is the nutating “wobble motion.” The inertia forces due to this motion always require, in high-speed applications, a pair of two nutating gears back to back with a phase shift of 180°. Such a timed relationship between the two nutating gears accomplishes a complete cancellation of the inertia forces.

The fascination of planetary gears and differentials led to a third development presented in Chapter 6 of this book. They are three-dimensional planetary transmissions. Their function becomes more complex if a second differential is placed around the first differential. Depending on the way some of the differential gears are connected to each other or constraint to the housing, very low or very high ratios can be realized. An example of a double-differential with a ratio of 78 is shown (Fig. 16). Next to the easy realization of high ratios, there are tangible advantages of double-differentials versus conventional gear reductions. It begins with the natural reduction of the relative speed between the gears in mesh due to the carrier rotation. Higher input

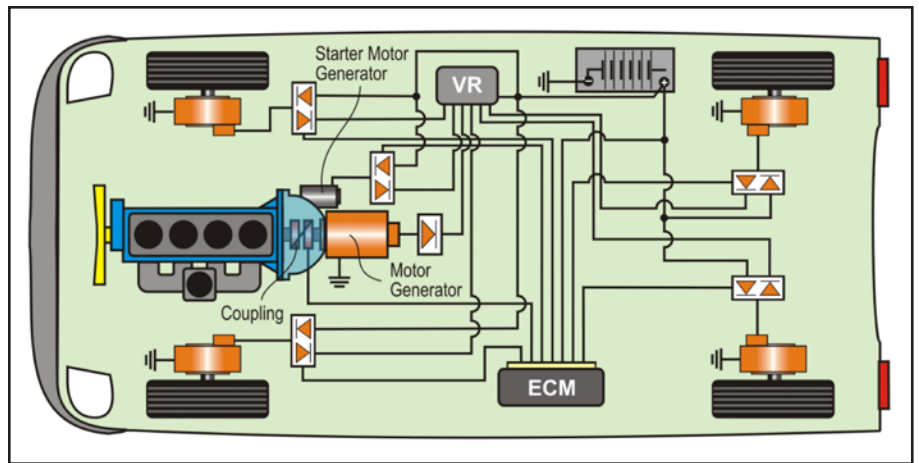

Figure 13 Hybrid vehicle with in-wheel electric motors (Ref. 13).

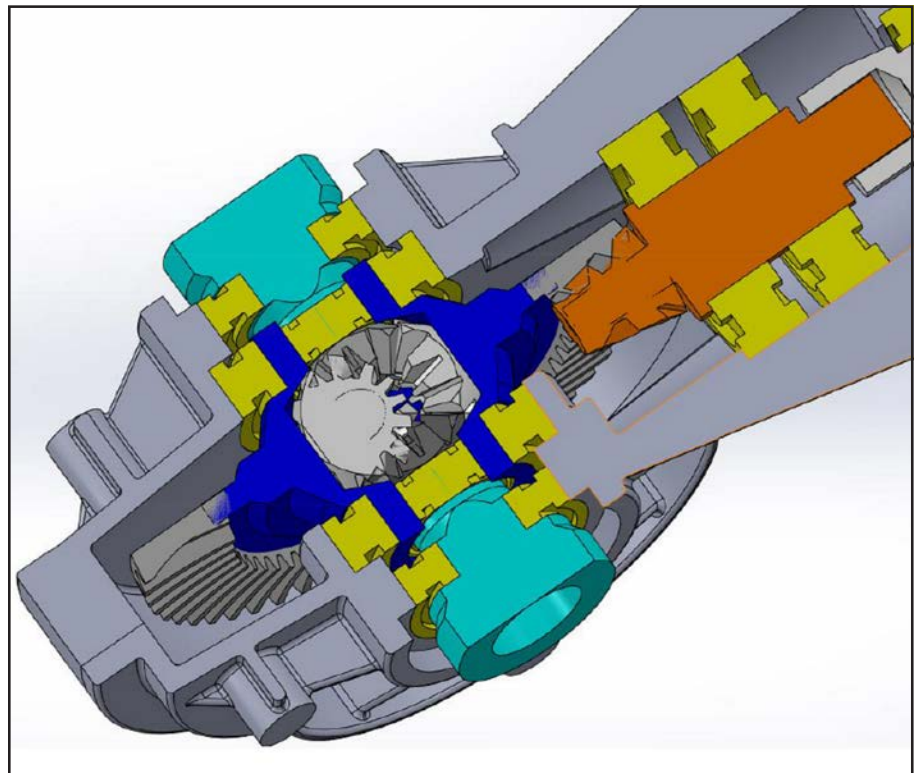

Figure 14 Single-stage electric vehicle hypoid transmission (Ref. 9).

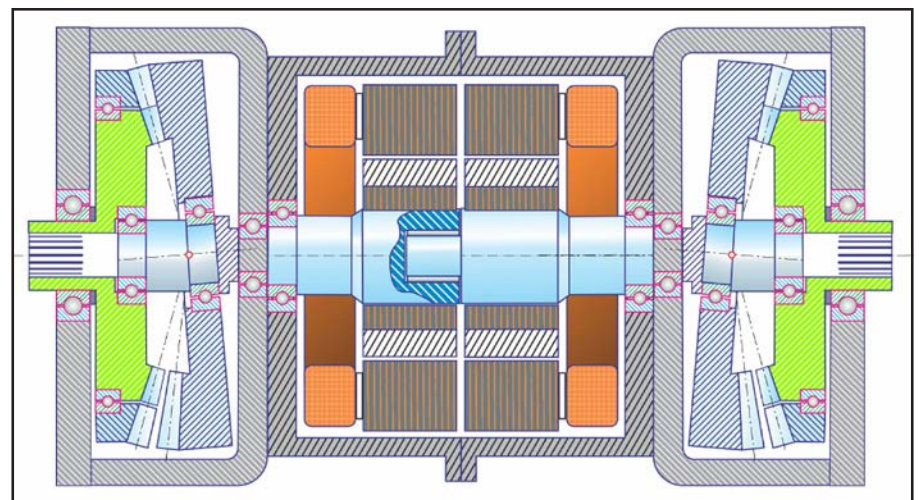

Figure 15 Reversed-pericyclic transmission.



speeds are permissible because the relative rotational speed between the meshing gears is about 50% of the input speed. Also, the contact forces are reduced to 50% because the torque is always transmitted by two equal opposite gears. Transmission housing deflections are symmetric and will only increase the size of the transmission housing without any warping.

### For more information.

Questions or comments regarding this paper? Contact Dr. Hermann Stadtfeld — [hstadteld@gleason.com](mailto:hstadteld@gleason.com).

### References

1. "8-Speed Automatic Transmission", ZF Friedrichshafen AG, [www.zf.com/products/en/cars/products\\_29289.html](http://www.zf.com/products/en/cars/products_29289.html), December 2019.
2. McGuinn, J., "New Transmissions Make the Gras GREENER", *Gear Technology Magazine*, July 2015, pp. 20–26.
3. "GKN brings supercar hybrid technology to mass market", Electric Vehicles Research, [www.electricvehiclesresearch.com/articles/9199/gkn-brings-supercar-hybrid-technology-to-mass-market/](http://www.electricvehiclesresearch.com/articles/9199/gkn-brings-supercar-hybrid-technology-to-mass-market/), March 2016.
4. "Innovative light-weight torque vectoring transmission for Visio.M: Perfect torque distribution for safe driving", Technical University of Munich, Research News, [www.tum.de/nc/en/about-tum/news/press-releases/details/31853/](http://www.tum.de/nc/en/about-tum/news/press-releases/details/31853/), October 2014.
5. "Personal Mobility, Then and Now", General Motors Heritage Center, [www.gmheritagecenter.com/featured/1969\\_Experimentals.html](http://www.gmheritagecenter.com/featured/1969_Experimentals.html), January 2020.
6. Brooks, R., "GKN Offers New eDrive Technology, Will Build New Plant", *Forging Magazine*, [www.forgingmagazine.com/forming/article/21924101/gkn-offers-new-edrive-technology-will-build-new-plant](http://www.forgingmagazine.com/forming/article/21924101/gkn-offers-new-edrive-technology-will-build-new-plant), September 2017.
7. Granzow, C., "Driving precision by torque vectoring — the new ZF axle drive.", Pete, C., 8th European all-wheel drive congress, Graz, Austria, 2007, Gruhle, W., pp. 1–12.
8. Hampel, C., "Magna working on next gen electric motor", *Electrive.com*, [www.electrive.com/2019/11/04/magna-working-on-next-gen-electric-motor/](http://www.electrive.com/2019/11/04/magna-working-on-next-gen-electric-motor/), November 4th, 2019.
9. Stadtfeld, H.J., "Electric Vehicle Transmission with Hypoid Gearset" Dinner, H., AGMA Fall Technical Meeting, Detroit, MI, 19FTM01, October 2019.
10. "Protean Drive", Protean Electric Corporation [www.proteanelectric.com/technology/](http://www.proteanelectric.com/technology/), January 2020.
11. "World's first transmission-equipped wheel hub motor" NSK Ltd. YouTube Video Dec. 2019.
12. "Urban Connection: The new Mitsubishi i-MiEV", Mitsubishi Motors, [www.mitsubishi-motors.com/en/showroom/i-miev/](http://www.mitsubishi-motors.com/en/showroom/i-miev/) December 2019.
13. Stadtfeld, H.J. "Automotive Drive Concepts", Company Publication, The Gleason Works, April 2008.

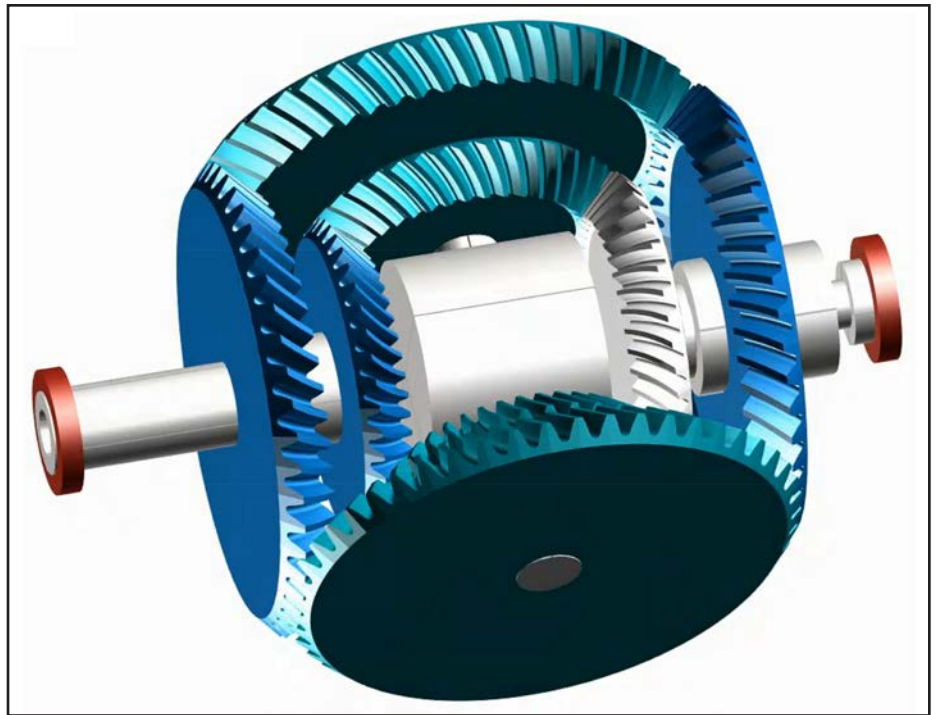
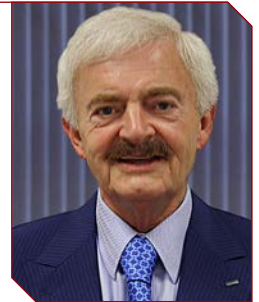

Figure 16 Double-differential transmission with ratio 78.

**Dr. Hermann J. Stadtfeld** is the Vice President of Bevel Gear Technology and R&D at the Gleason Corporation and Professor of the Technical University of Ilmenau, Germany. As one of the world's most respected experts in bevel gear technology, he has published more than 300 technical papers and 10 books in this field. Likewise, he has filed international patent applications for more than 60 inventions based upon new gearing systems and gear manufacturing methods, as well as cutting tools and gear manufacturing machines. Under his leadership the world of bevel gear cutting has converted to environmentally friendly, dry machining of gears with significantly increased power density due to non-linear machine motions and new processes. Those developments also lower noise emission level and reduce energy consumption.



For 35 years, Dr. Stadtfeld has had a remarkable career within the field of bevel gear technology. Having received his Ph.D. with summa cum laude in 1987 at the Technical University in Aachen, Germany, he became the Head of Development & Engineering at Oerlikon-Bührle in Switzerland. He held a professor position at the Rochester Institute of Technology in Rochester, New York from 1992 to 1994. In 2000 as Vice President R&D he received in the name of The Gleason Works two Automotive Pace Awards — one for his high-speed dry cutting development and one for the successful development and implementation of the Universal Motion Concept (UMC). The UMC brought the conventional bevel gear geometry and its physical properties to a new level. In 2015, the Rochester Intellectual Property Law Association elected Dr. Stadtfeld the "Distinguished Inventor of the Year." Between 2015–2016 CNN featured him as "Tech Hero" on a Website dedicated to technical innovators for his accomplishments regarding environmentally friendly gear manufacturing and technical advancements in gear efficiency.

Stadtfeld continues, along with his senior management position at Gleason Corporation, to mentor and advise graduate level Gleason employees, and he supervises Gleason-sponsored Master Thesis programs as professor of the Technical University of Ilmenau — thus helping to shape and ensure the future of gear technology.

For Related Articles Search

electric vehicles

at [www.geartechnology.com](http://www.geartechnology.com)