

# Mapping the World of Manufacturing

**After decades of iteration, you might think manufacturing software suites are running out of new modules to add, but improving hardware is opening up new avenues for them to explore.**

Alex Cannella, Associate Editor

Every month, press releases for engineering software show up in our inbox, extolling the latest advances and most cutting edge modules just introduced to the suite. Every month, we find something new to design, measure, calculate and simulate mechanical components. And when you look at some of these software suites, they've been doing this consistently for years, decades even. KISSsoft alone has roughly 190 different calculation modules covering everything from gears to bearings.

Which raises the question: With such comprehensive software, what could even possibly be left? What corners of the mechanical universe have we not somehow mapped yet?

The simple answer is, probably unsurprisingly, that we still have plenty of places. The more interesting answer, from Dr. Stefan Beermann, CEO of KISSsoft AG, is that we will never just run out of new designs to make. Or at least, in the field of gearing, we won't.

"There are some standard gears out there you can buy, but usually a gear is not a standard part," Beermann said. "It's something which is designed to a specific purpose. Each time, freshly. Of course, based on experience you have before, usually you modify something... We won't run into the situation that we won't design gears anymore. It might be always the same criteria or the same software we're using, but this will be an ongoing job to design new gears because the requirements keep changing."

As with anything else, gear designs are constantly being improved and technology is pushing the limits of what we can make with them. Machinery is

getting more accurate, allowing gears to be cut more precisely and run more quietly, combating a primary issue that many gear manufacturers deal with. Gears are getting smaller and stronger. They're made from new steel alloys and undergo new heat treatment techniques. Every step of the process is always being improved, and software needs to incorporate those improvements. Even if a software suite already has a module to calculate the dimensions of a double helical gear, it's still important to update the software to account for how a new cutting or heat treatment technique might affect the workpiece.

And that's just accounting for the march of technology, not even customer demand or regulations. ISO standards change regularly, including the relatively recent changes relating to micropitting and flank fractures for gears. While these types of failure mode have always been around, we've only recently started finding ways to deal with them. As the gear community develops new requirements for best practices, gear design software has to change to account, such as KISSsoft did when it implemented ISO standards for calculation methods treating micropitting and flank fracture in its software a few years ago.

While the day-to-day work of keeping up with the latest in the industry may be a primary focus at KISSsoft, that doesn't mean they're out of modules to develop, either. On the contrary, improving computer hardware is opening up more and more new avenues for the company to explore. There are a lot of calculation methods that, while technically possible, take so long that they're impractical to actually utilize. But as computer hardware grows more powerful, software companies at last have the tools to start exploring these new avenues.

According to Beermann, the computing power of yesteryear made this a complete impracticality, something that would take weeks to calculate, but with today's hardware, they've gotten the process down to just a matter of hours.

KISSsoft is also working to merge its individual calculating processes into a



Whole system simulation is one of the advanced features offered by KISSsoft.

single model. A growing focus is on tying these disparate modules together, either to allow multiple calculations for a single workpiece to be shown at once, or to allow the simulation of full systems of parts.

“We’re still not there that we can model everything exactly in full reality—this will never be possible—but it’s getting closer and closer to that point,” Beermann said.

In particular, Beermann is seeing a trend towards modeling an entire system, such as an entire gearbox, which means modeling and calculating for every individual part in that system—simultaneously. When you have to calculate an entire system at once instead of just a single workpiece, the computing power required increases exponentially, but here again, we’re reaching the point where hardware is finally getting strong enough to accomplish exactly that. The most recent and complex example that Beermann has seen was a model of a complete drive train for a tractor, and applications are only bound to get more complex from here on out.

With gears especially, you can’t design a part without knowing how it’s going to be manufactured, and the connection between gear design software and the machines and tooling used to manufacture the parts is extremely important. That’s one of the key reasons KISSsoft was acquired by the Gleason Corporation in 2017. It’s also why KISSsoft now integrates with the GEMS software that runs Gleason machine tools.

That integration between design and manufacturing are where other software providers also find their niche.

HyGEARS, developed by Involute Simulation Softwares Inc., is 3-D gear engineering software for the design, kinematic analysis, optimization and manufacturing of a wide range of gear types. HyGEARS’ niche seems to be flexibility. “HyGEARS is manufacturer independent,” says Dr. Claude Gosselin, president of Involute Simulation Softwares, “which means that the user can have gear cutting machinery from different sources on the shop floor and still be able to address significant production batch sizes for different gear types without the need for the machine manufacturer’s software.”

According Gosselin, small- and even some medium-sized manufacturers are

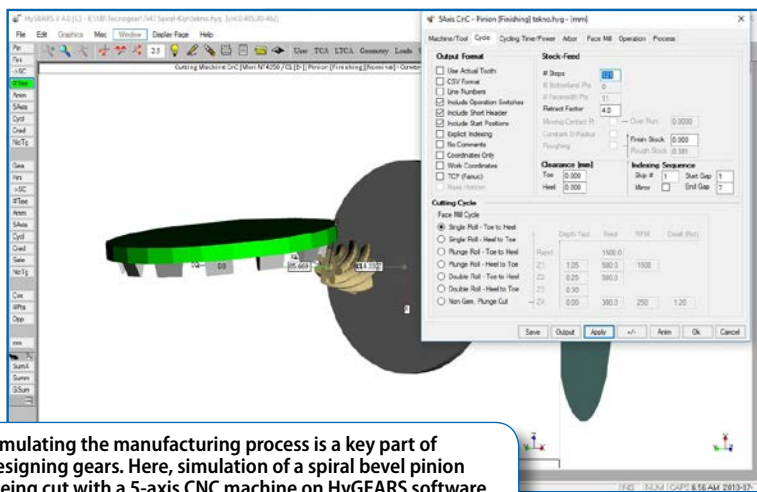

Simulating the manufacturing process is a key part of designing gears. Here, simulation of a spiral bevel pinion being cut with a 5-axis CNC machine on HyGEARS software.

PTC  
MDA  
ASIA

## POWER TRANSMISSION AND CONTROL 2018

International Trade Fair for Hydraulic, Pneumatics, Sealing, Gear, Motor, Chain, Belt, Bearings and Springs.

6 - 9 November 2018 Shanghai New Int'l Expo Centre  
ptc-asia.com

### Driven to be SMART



#### For further information, please contact:

Deutsche Messe AG		
Messagelände, 30521 Hannover, Germany		
Contact: Meike Sauer	Tel. +49-511-89 34114	Email: meike.sauer@messe.de
Website: messe.de	Fax +49-511-89 39681	
Hannover Milano Fairs Shanghai Ltd.		
Rm. 301 B&Q Pudong Office Tower 393 Yinxiao Rd. Pudong		
Shanghai 201204, P.R. China		
Contact: Ms. Ally Huang/ Mr. Jimmy Yang/ Ms. Wo Zhao/ Ms. Sophia Bo/ Ms. Sunny Sun/ Mr. Martin Xu	Tel. +86-21 5045 6700*252/225/215/322/251/558	Email: ptc-asia@hmf-china.com
	Fax +86-21 5045 9355 / 6886 2355	Website: ptc-asia.com

left with only a few options. You can pick niche software that might only work for one or two types of gears, or just bearings, or whatever you're looking for. And if you get an order for something outside of that software suite, you have to make do and hope you have a technician with the experience to set up machines manually. Or you can go for a more comprehensive software suite that can cross those lines, but it doesn't come cheap.

For smaller manufacturing outlets in particular, that's a tough call. On the one hand, smaller parts manufacturers, especially gear manufacturers, have to deal with differing sizes of lots and types of parts on a frequent basis. On paper, larger outfits can churn out large lots of one gear all day, while smaller manufacturers that don't have that economy of scale instead have to take on many different, smaller orders, which means they're the ones that need that flexibility most. But they're also the ones without a massive operating budget, meaning the high price tag of an all-inclusive software suite that would offer that flexibility would be more onerous for them. Purchasing multiple pieces of software is equally financially prohibitive, reaching the same levels of costliness where you might as well just buy the single, comprehensive suite.

"For a number of companies, it is dramatic," Gosselin said. "If you even, at 38 to 40 grand, which is the typical selling price for HyGEARS, some manufacturers just decide not to go ahead because they can't afford that amount of money... In some cases, I'll lose the sale because even my price is too high, so if you compare this with other software, it's totally out of reach. I think this makes quite a significant difference into what people can afford to do or get to do."

Now, this all is a burden that's largely placed on small manufacturers, not necessarily the part buyers they cater to. But it does create an environment where specialization in a certain field is gently encouraged, and the effect of that can theoretically extend down the line. Software is a vital part of the manufacturing chain, so if manufacturers can't afford software that can manufacture

parts in multiple fields, that means fewer multi-specialist manufacturers you can buy from, and having to shop around for more individual parts cobbled together from multiple shops.

Now, none of this is to suggest that we're entering an apocalyptic scenario where we're going to wake up tomorrow and notice small manufacturers have been squeezed to death by software prices. Far from it! But as with any other system, the industry can always be improved, and this highlights an underserved area that software developers have an opportunity to grow into.

It's also an area that Gosselin is trying to explore. He's working to make HyGEARS an affordable software suite that can break some of those barriers. The software can't handle every gear under the sun, but it can work with a wide range of bevel and helical gears, as well as involute splines, face gears, and spiral face clutches. But that's only for now. The most recent step HyGEARS has made is a leap into couplings, expanding support to cover Hirth coupling and clogged teeth couplings. And much like KISSsoft, HyGEARS is working to keep with the times, adding support for Skiving, for example.

Gosselin has also found success with HyGEARS helping parts buyers start manufacturing their own parts instead of shopping around for them.

"Some HyGEARS customers [small companies] used to buy from outside vendors," Gosselin said. "After purchasing the correct software (HyGEARS in this case), combined to in-house 5-axis CNC machines, they became self sufficient: they now control the design and manufacturing and their products offer consistency."

HyGEARS, of course, isn't the only affordable option on the block. MESYS is similarly trying to offer an affordable alternative to massive, all-encompassing software suites. Unlike HyGEARS, however, MESYS' primary domain is shaft system and bearing calculations, and they're sticking to what they specialize in. As a younger program compared

to other options on the market, originally released in 2010, MESYS still has plenty of room to potentially expand, but the focus currently is on improving their already existing features.

"There are companies that don't need the whole range. There are customers who are just bearing manufacturers," Markus Raabe, director and owner of MESYS, said. "They want bearing calculations and they need shaft calculation because the bearing is not alone. They don't need gear strength calculations... If it were just standard gear ratings according to ISO 6336 or AGMA 2001, there are many programs on the market. Better deliver something that is not available in other programs."

It's an opposite view from Gosselin's, but here again, seeking out a niche where there isn't as much competition makes perfect sense from a business perspective.

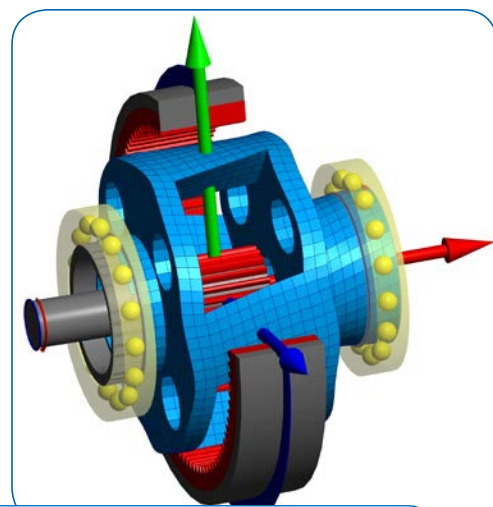

MESYS software specializes in the simulation of elastic deformation, as shown in this carrier body example.

So what has MESYS been doing to improve in their field? Like other software companies, MESYS' main focus recently has been on expanding the software's ability to do integrated finite element calculations.

"For several years now, it was possible to import a housing step file that is both meshed and reduced within the software and then it could be considered as a housing stiffness," Raabe said. "Now this is extended so that not only reduction is done to one node for a bearing ring, but elastic deformations

of the bearing ring can be considered, and also that elastic deformation of gears can be considered.”

But while MESYS might be taking an opposite approach from HyGEARS, they do still make concessions towards interconnectivity with other software. Namely, it doesn't feature gear strength calculations of its own, but is designed to be able to connect with gear calculation suites. Namely, MESYS integrates with eAssistant and TBK software from GWJ Technology, as well as the Gear Production Suite produced by Dontyne Systems. MESYS may be focusing on specializing, but they're also not siloing their software away.

Camnetics follows many of the same patterns that other companies do. They produce gear design software that's intended to be used for manufacturing. Their GearTrax and GearTeq software is used to create solid models of gear components for easy inclusion into CAD programs.

Gregory Hottman, president of Camnetics, highlighted several parts such as worm wheels and spiral bevel

gears that they're working to improve the accuracy of their models for. Currently, Hottman recommends the software only be used to model these more complicated gears.

“When they're cutting the tooth on a machine, there's overcutting and undercutting going on that the machine can compensate for,” Hottman said. “We really can't compensate for that in the CAD world yet.”

But Hottman wants to change that. It's still an ongoing process, but Camnetics has already made some efforts towards tackling the issue. Most notably, Camnetics has added a cavity cut method that extracts cutter parts to the gear model.

Meanwhile, they're also looking to expand into simulating full gear sets for cycloidal gears. Currently, Camnetics can do a cycloidal gear with a pin, but they're working to expand that.

While not quite on the same level as simulating an entire drivetrain, it's still a move in the same direction other software developers are going: expanding to include more moving parts, which

is the current frontier for the bleeding edge of software development.

But more interestingly, once you look under the gloss of the big software companies pushing the boundaries of the field, you see other gaps like what Gosselin is trying to fill with HyGEARS, areas where the limitations aren't technology, but economics. It's a different beast to wrestle with, but it's no less of an important one. **PTE**

**For more information:**

Camnetics  
Phone: (608) 835-2378  
[www.camnetics.com](http://www.camnetics.com)

HyGEARS  
[Hygears@hygears.com](mailto:Hygears@hygears.com)  
[www.hygears.com](http://www.hygears.com)

KISSsoft AG (A Gleason Company)  
Phone: +41 55 254-2050  
[www.kisssoft.com](http://www.kisssoft.com)

MESYS  
Phone: +41 44 455-6800  
[www.MESYS.ag](http://www.MESYS.ag)



# Power Transmission Solutions

*Sesame Motor lines of AC motors, gear motors, gear reducers and servo planetary gearheads offer a wide variety of size, precision levels and configurations to satisfy the full range of motion control applications. With years of manufacturing experience, we can assist in selecting the best part for your need and customization to your exact specifications.*



 **SESAME**  
[www.sesamemotor.com](http://www.sesamemotor.com)



 **IMTS2018**  
East Building, Level 3  
Booth: 134644

America Exclusive Agent  
**DIEQUA**  
Corporation  
630-980-1133  
[www.diequa.com](http://www.diequa.com)

